

# APÉNDICE A

## Digilent D2-SB System Board Reference Manual

June 4, 2004



www.digilentinc.com

246 East Main | Pullman, WA 99163  
(509) 334 8306 Voice and Fax

### Overview

The Digilent D2-SB circuit board provides a complete circuit development platform centered on a Xilinx Spartan 2E FPGA. D2-SB features include:

- A Xilinx XC2S200E-200 FPGA with 200K gates and 350MHz operation;
- 143 user I/Os routed to six standard 40-pin expansion connectors;
- A socket for a JTAG-programmable 18V02 configuration Flash ROM;
- Dual on-board 1.5A power regulators (1.8V and 3.3V);
- An SMD 50MHz oscillator, and a socket for a second oscillator;
- A JTAG programming port;
- A status LED and pushbutton for basic I/O.

The D2-SB has been designed to work seamlessly with all versions of the Xilinx ISE CAD tools, including the free WebPack tools available from the Xilinx website. A growing collection of low-cost expansion boards can be used with the D2-SB to add analog and digital I/O capabilities, as well as various data ports like Ethernet and USB. The D2-SB board ships with a power supply and programming cable, so designs can be implemented immediately without the need for any additional hardware.

### Functional Description

The Digilab D2-SB provides a minimal system that can be used to rapidly implement FPGA-based circuits, or to gain exposure to Xilinx CAD tools and Spartan 2E devices. The D2-SB provides only the essential supporting devices for the Spartan 2E FPGA, including clock sources and power supplies. All available I/O signals are routed to standard expansion

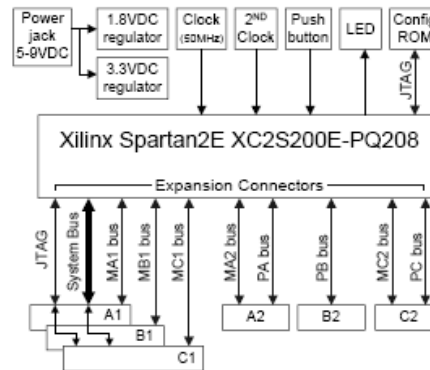

Figure 1. D2-SB Circuit Board Block Diagram

connectors that mate with 40-pin, 100 mil spaced DIP headers available from any catalog distributor. A pushbutton and LED are also included for basic I/O. (See Figure 1)

The D2-SB board has been designed to serve primarily as a host for peripheral boards. Each of the six expansion connectors provides the unregulated supply voltage (VU), 3.3V, GND, and 32 FPGA I/O signals. Because there are more connector pins than FPGA pins, the A1, B1 and C1 connectors share an 18-pin "system bus", and not all pins on the B expansion connectors are used. JTAG signals are also routed to the A1, B1, and C1 expansion connectors. This allows peripheral boards to drive the scan chain, or to be configured along with the Spartan 2E FPGA.

Application-specific peripheral boards can be created to mate with the D2-SB, or ready-made peripheral boards that offer many

standard functions can be obtained from Digilent (see [www.digilentinc.com](http://www.digilentinc.com)).  
**JTAG Ports and Device Configuration**

The Spartan 2E FPGA, the 18V00 ROM on the D2-SB, and any programmable devices on peripheral boards attached to the D2-SB can be programmed via the JTAG port. The JTAG scan chain is routed to the FPGA and ROM on the D2-SB and then around the board to four connection ports as shown in Figure 2. The primary configuration port (Port 1) uses a standard 6-pin JTAG header (J7) that can accommodate Digilent's JTAG3 cable (or cables from Xilinx or other vendors). The other three JTAG programming ports are available on the A1, B1, and C1 expansion connectors, and these ports are bi-directional. If no peripheral board is present, a buffer on the D2-SB removes the expansion connector from the JTAG chain. If a peripheral board with a JTAG device is attached, the scan chain is driven out the expansion connector so that any JTAG-programmable parts can be configured. If a Digilent port module is connected to one of the three JTAG-enabled expansion connectors, then the port module can drive the JTAG chain to program all devices in the scan chain (port modules include Ethernet, USB, EPP parallel, and serial modules — see [www.digilentinc.com](http://www.digilentinc.com) for more information).

The scan chain can be driven from the primary port by powering on the D2-SB, connecting it to a PC with a JTAG programming cable, and running the "auto-detect" feature of the configuration software. The configuration software allows devices in the scan chain to be selectively programmed with any available configuration file. If no programming ROM is loaded in the IC5 socket (or if ROM is present but is not to be included in the scan chain), jumper-shunts must be loaded at JP1 and JP2 in the "Bypass ROM" location to route the JTAG chain around the ROM socket. If an 18V02 (or larger) ROM is loaded in the IC5 socket, it can be included in the scan chain by loading the JP1 and JP2 jumper-shunts in the "Include ROM" positions.

If a programming ROM is present in the IC5 socket, the FPGA will automatically access the

ROM for configuration data if jumper shunts are loaded in all three positions of J8 (M2, M1, and M0).

Port modules attached to ports A1, B1, or C1 can drive the scan chain if a jumper-shunt is installed on the primary JTAG header across the TDI and TDO pins. In their default state, Digilent port modules will appear as a JTAG cable to the configuration software. Port modules can disable their JTAG drivers; if more than one JTAG driver is enabled on the scan chain, programming may fail.

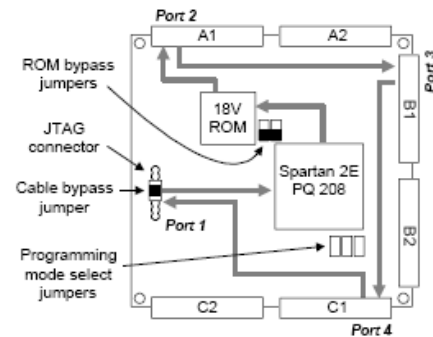

Figure 2. JTAG Signal Routing on D2-SB

#### Power Supplies

The D2-SB board uses two LM317 voltage regulators to produce a 1.8VDC supply for the Spartan 2E core, and 3.3VDC supply for the I/O ring. Both regulators have good bypass capacitance, allowing them to supply up to 1.5A of current with less than 50mV of noise (typical). Power can be supplied from a low-cost wall transformer supply. The external supply must use a 2.1mm center-positive connector, and it must produce between 6VDC and 12VDC of unregulated voltage.

The D2-SB uses a four layer PCB, with the inner layers dedicated to VCC and GND planes. Most of the VCC plane is at 3.3V, with an island under the FPGA at 1.8V. The FPGA and the other ICs on the board all have 0.047uF bypass capacitors placed as close as possible to each VCC pin.

Total board current is dependant on FPGA configuration, clock frequency, and external connections. In test circuits with roughly 50K gates routed, a 50MHz clock source, and a single expansion board attached (the DIO5 board), approximately 200mA +/- 30% of supply current is drawn from the 1.8V supply, and approximately 200mA +/- 50% is drawn from the 3.3V supply. These currents are strongly dependent on FPGA and peripheral board configurations.

All FPGA I/O signals use the VCCO voltage derived from the 3.3V supply. If other VCCO voltages are required, the regulator output can be modified by changing R12 according to:

$$VCCO = 1.25(1 + R12/R11).$$

Refer to the LM317 data sheet and D2-SB schematic for further information.

### Oscillators

The D2-SB provides a 50MHz SMD primary oscillator and a socket for a second oscillator. The primary oscillator is connected to the GLK2 input of the Spartan 2E (pin 182), and the secondary oscillator is connected to GCLK3 (pin 185). Both clock inputs can drive the DLL on the Spartan 2E, allowing for internal frequencies up to four times higher than the external clock signals. Any 3.3V oscillator in a half-size DIP package can be loaded into the secondary oscillator socket.

### Pushbutton and LED

A single pushbutton and LED are provided on the board allowing basic status and control functions to be implemented without a peripheral board. As examples, the LED can be illuminated from a signal in the FPGA to verify that configuration has been successful, and the pushbutton can be used to provide a basic reset function independent of other inputs. The circuits are shown in Figure 2.

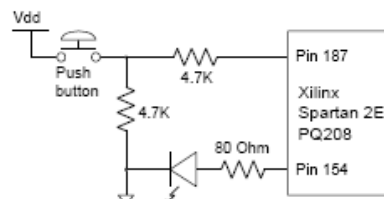

Figure 2. Pushbutton and LED Circuit

### Expansion Connectors

The six expansion connectors labeled A1-A2, B1-B2, and C1-C2 use 2x20 right-angle headers with 100 mil spacing. All six connectors have GND on pin 1, VU on pin 2, and 3.3V on pin 3. Pins 4-35 route to FPGA I/O signals, and pins 36-40 are reserved for JTAG and/or clock signals. (See Figure 4.)

The expansion headers provide 192 signal connections, but the Spartan 2E-PQ208 has only 143 available I/O signals. Thus, some FPGA signals are routed to more than one connector. In particular, the lower 18 pins (pins 4-21) of the A1, B1, and C1 connectors are all connected to the same 18 FPGA pins, and they are designated as the "system bus" (a unique chip select signal is routed to each connector). Other than these 18 shared signals, all remaining FPGA signals are routed to individual expansion connector positions. The lower 18 pins of the A2, B2, and C2 connectors are designated as "peripheral busses", and each of these busses (named PA, PB, and PC) use 18 unique signals.

The 14 upper pins of each expansion connector (pins 22-35) have been designated as "module busses". The A1, A2, C1, and C2 connectors each have fully populated module busses (named MA1, MA2, MC1, and MC2). Insufficient FPGA pins were available to route full module busses to the B connectors; only the 8 data pins of MB1 are routed, and no pins are routed to the upper B2 expansion connector (i.e., MB2 is a "no connect").

**System Bus**

The "system bus" is a protocol used by certain expansion boards that mimics a simple 8-bit microprocessor bus. It uses eight data lines, six address lines, a write-enable (WE) strobe that can be used by the peripheral to latch written data, an output-enable (OE) strobe that

can be used by the peripheral to enable read data, a chip select, and a clock to enable synchronous transfers. The diagrams, (Figure 3), below show signal timings assumed by Diligent to create peripheral devices. However, any bus and timing models can be used by modifying circuits in the FPGA and attached peripheral devices.

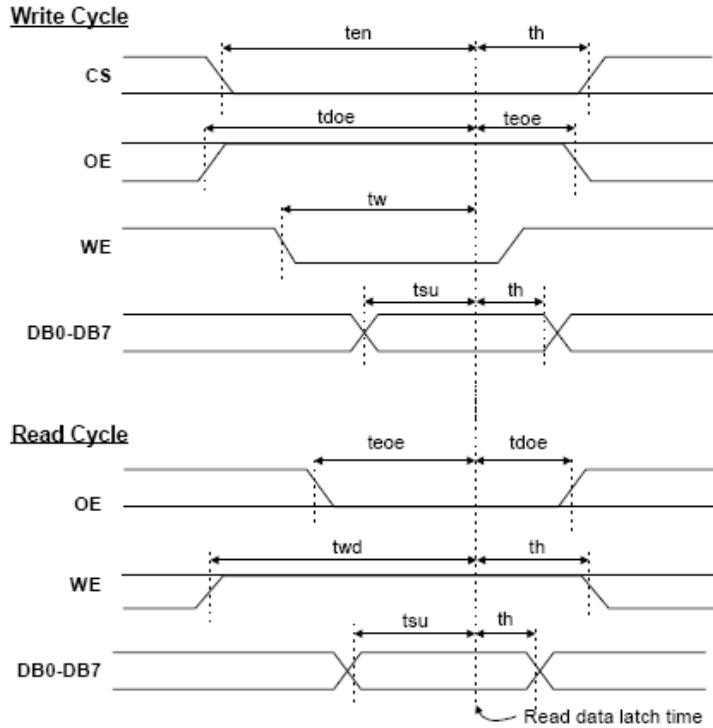

Figure 3. System Bus Timing

Table 1. System Bus Timing		
Symbol	Parameter	Time (typ)
$t_{en}$	Time to enable after CS asserted	10ns
$t_h$	Hold time	1ns
$t_{doe}$	Time to disable after OE de-asserted	10ns
$t_{eoe}$	Time to enable after OE asserted	15ns
$t_w$	Write strobe time	10ns
$t_{su}$	Data setup time	5ns
$t_{wd}$	Write disable time	0ns

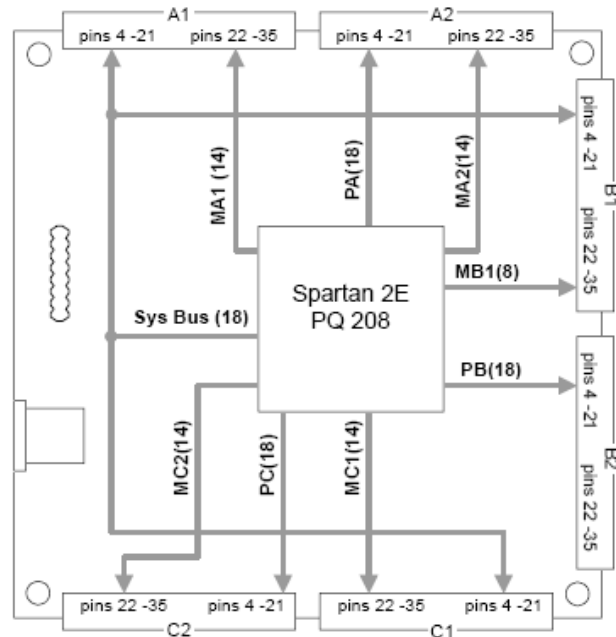

Figure 4. Expansion Connector Signal Routing

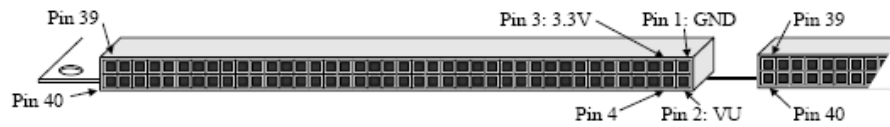

Figure 5. Expansion Connector Pin Locations

Table 2. D2-SB Expansion Connector Pinout

Pin #	A1		A2		B1		B2		C1		C2	
	Signal	FPGA Pin	Signal	FPGA Pin	Signal	FPGA Pin	Signal	FPGA Pin	Signal	FPGA Pin	Signal	FPGA Pin
1	GND		GND		GND		GND		GND		GND	
2	VU		VU		VU		VU		VU		VU	
3	VCC33		VCC33		VCC33		VCC33		VCC33		VCC33	
4	ADR0	112	PAI01	182	ADR0	112	PBI01	71	ADR0	112	PCI01	23
5	DB0	111	PAI02	181	DB0	111	PBI02	70	DB0	111	PCI02	22
6	ADR1	110	PAI03	180	ADR1	110	PBI03	69	ADR1	110	PCI03	21
7	DB1	109	PAI04	152	DB1	109	PBI04	68	DB1	109	PCI04	20
8	ADR2	108	PAI05	151	ADR2	108	PBI05	64	ADR2	108	PCI05	18
9	DB2	102	PAI06	150	DB2	102	PBI06	63	DB2	102	PCI06	17
10	ADR3	101	PAI07	149	ADR3	101	PBI07	62	ADR3	101	PCI07	16
11	DB3	100	PAI08	148	DB3	100	PBI08	61	DB3	100	PCI08	15
12	ADR4	99	PAI09	147	ADR4	99	PBI09	60	ADR4	99	PCI09	11
13	DB4	98	PAI010	146	DB4	98	PBI010	59	DB4	98	PCI010	10
14	ADR5	97	PAI011	145	ADR5	97	PBI011	58	ADR5	97	PCI011	9
15	DB5	96	PAI012	141	DB5	96	PBI012	57	DB5	96	PCI012	8
16	WE	95	PAI013	140	WE	95	PBI013	56	WE	95	PCI013	7
17	DB6	94	PAI014	139	DB6	94	PBI014	55	DB6	94	PCI014	6
18	OE	93	PAI015	138	OE	93	PBI015	49	OE	93	PCI015	5
19	DB7	89	PAI016	136	DB7	89	PBI016	48	DB7	89	PCI016	4
20	CSA	181	PAI017	135	CSB	88	PBI017	47	CSC	45	PCI017	3
21	LSBCLK	87	PAI018	134	LSBCLK	87	PBI018	46	LSBCLK	87	PCI018	206
22	MA1DB0	180	MA2DB0	133	MB1DB0	86			MC1DB0	44	MC2DB0	205
23	MA1DB1	179	MA2DB1	132	MB1DB1	84			MC1DB1	43	MC2DB1	204
24	MA1DB2	178	MA2DB2	129	MB1DB2	83			MC1DB2	42	MC2DB2	203
25	MA1DB3	176	MA2DB3	127	MB1DB3	82			MC1DB3	41	MC2DB3	202
26	MA1DB4	175	MA2DB4	126	MB1DB4	81			MC1DB4	40	MC2DB4	201
27	MA1DB5	174	MA2DB5	125	MB1DB5	75			MC1DB5	36	MC2DB5	200
28	MA1DB6	173	MA2DB6	123	MB1DB6	74			MC1DB6	35	MC2DB6	199
29	MA1DB7	169	MA2DB7	122	MB1DB7	73			MC1DB7	34	MC2DB7	198
30	MA1ASTB	168	MA2ASTB	121					MC1ASTB	33	MC2ASTB	194
31	MA1DSTB	167	MA2DSTB	120					MC1DSTB	31	MC2DSTB	193
32	MA1WRT	166	MA2WRT	116					MC1WRT	30	MC2WRT	192
33	MA1WAIT	165	MA2WAIT	115					MC1WAIT	29	MC2WAIT	191
34	MA1RST	164	MA2RST	114					MC1RST	27	MC2RST	189
35	MA1INT	163	MA2INT	113					MC1INT	24	MC2INT	188
36	JTSELA				JTSELB				JTSELC			
37	TMS				TMS				TMS			
38	TCK				TCK				TCK			
39	TDO		GCLK0	80	TDO				TDO		GCLK1	77
40	TDI		GND		TDI				TDI		GND	

Pin #	Function	Pin #	Function	Pin #	Function	Pin #	Function
1	GND	53	VCCO	105	VCCO	157	TDO
2	TMS	54	M2	106	PROG	158	GND
3	PC-IO17	55	PB-IO14	107	INIT	159	TDI
4	PC-IO16	56	PB-IO13	108	ADR2	160	PA-IO3
5	PC-IO15	57	PB-IO12	109	DB1	161	PA-IO2
6	PC-IO14	58	PB-IO11	110	ADR1	162	PA-IO1
7	PC-IO13	59	PB-IO10	111	DB0	163	MA1-INT
8	PC-IO12	60	PB-IO9	112	ADR0	164	MA1-RST
9	PC-IO11	61	PB-IO8	113	MA2-INT	165	MA1-WAIT
10	PC-IO10	62	PB-IO7	114	MA2-RST	166	MA1-WRT
11	PC-IO9	63	PB-IO6	115	MA2-WAIT	167	MA1-DSTB
12	GND	64	PB-IO5	116	MA2-WRT	168	MA1-ASTB
13	VCCO	65	GND	117	GND	169	MA1-DB7
14	VCCINTT	66	VCCO	118	VCCO	170	GND
15	PC-IO8	67	VCCINT	119	VCCINT	171	VCCO
16	PC-IO7	68	PB-IO4	120	MA2-DSTB	172	VCCINT
17	PC-IO6	69	PB-IO3	121	MA2-ASTB	173	MA1-DB6
18	PC-IO5	70	PB-IO2	122	MA2-DB7	174	MA1-DB5
19	GND	71	PB-IO1	123	MA2-DB6	175	MA1-DB4
20	PC-IO4	72	GND	124	GND	176	MA1-DB3
21	PC-IO3	73	MB1-DB7	125	MA2-DB5	177	GND
22	PC-IO2	74	MB1-DB6	126	MA2-DB4	178	MA1-DB2
23	PC-IO1	75	MB1-DB5	127	MA2-DB3	179	MA1-DB1
24	MC1-INT	76	VCCINT	128	VCCINT	180	MA1-DB0
25	GND	77	GCLK1	129	MA2-DB2	181	CSA
26	VCCO	78	VCCO	130	VCCO	182	GCLK2
27	MC1-RST	79	GND	131	GND	183	GND
28	VCCINT	80	GCLK0	132	MA2-DB1	184	VCCO
29	MC1-WAIT	81	MB1-DB4	133	MA2-DB2	185	GCLK3
30	MC1-WRT	82	MB1-DB3	134	PA-IO18	186	VCCINT
31	MC1-DSTB	83	MB1-DB2	135	PA-IO17	187	BTN
32	GND	84	MB1-DB1	136	PA-IO16	188	MC2-INT
33	MC1-ASTB	85	GND	137	GND	189	MC2-RST
34	MC1-DB7	86	MB1-DB0	138	PA-IO15	190	GND
35	MC1-DB6	87	LSSCLK	139	PA-IO14	191	MC2-WAIT
36	MC1-DB5	88	CSB	140	PA-IO13	192	MC2-WRT
37	VCCINT	89	DB7	141	PA-IO12	193	MC2-DSTB
38	VCCO	90	VCCINT	142	VCCINT	194	MC2-ASTB
39	GND	91	VCCO	143	VCCO	195	VCCINT
40	MC1-DB4	92	GND	144	GND	196	VCCO
41	MC1-DB3	93	OE	145	PA-IO11	197	GND
42	MC1-DB2	94	DB6	146	PA-IO10	198	MC2-DB7
43	MC1-DB1	95	WE	147	PA-IO9	199	MC2-DB6
44	MC1-DB0	96	DB5	148	PA-IO8	200	MC2-DB5
45	CSC	97	ADR5	149	PA-IO7	201	MC2-DB4
46	PB-IO18	98	DB4	150	PA-IO6	202	MC2-DB3
47	PB-IO17	99	ADR4	151	PA-IO5	203	MC2-DB2
48	PB-IO16	100	DB3	152	PA-IO4	204	MC2-DB1
49	PB-IO15	101	ADR3	153	DIN	205	MC2-DB0
50	M1	102	DB2	154	LED	206	PC-IO18
51	GND	103	GND	155	CCLK	207	TCK
52	M0	104	DONE	156	VCCO	208	VCCO